

* Please understand key indicators & functions at the first operation.

FRONT PANEL & KEY FUNCTIONS

VP: TRMS Volt Indicator
A: TRMS Amp Indicator
W: Watt Indicator
S: Apparent Power (VA) Indicator
Q: Reactive Power (Var) Indicator
PF: Power Factor Indicator
VL: Phase to Line Volt Indicator
K: Kilo Unit Indicator
M: Mega Unit Indicator
Max: Max. Hold Indicator

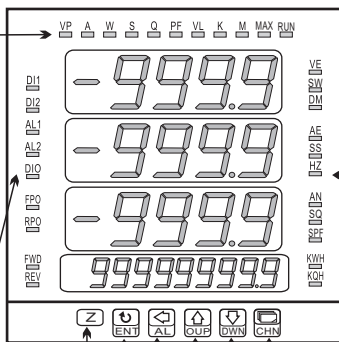

VE: 3 Phase Average Volt Indicator
ΣW: 3 Phase Equivalent Watt Indicator
DM: Demand Indicator
AE: 3 Phase Average Amp Indicator
ΣS: 3 Phase Equivalent Apparent Power (VA) Indicator
Hz: Frequency Indicator
AN: Amp of Neutral Indicator
ΣQ: 3 Phase Equivalent Reactive Power (Var) Indicator
ΣPF: 3 Phase Equivalent Power Factor Indicator
KWH: Kilo Watt-Hour Indicator
KQH: Kilo Var-Hour Indicator

D11: Digital Input 1 Indicator
D12: Digital Input 2 Indicator
AL1: Alarm 1 Indicator
AL2: Alarm 2 Indicator
DIO: Communication Indicator
FPO: Forward Pulse Output Indicator
RPO: Reverse Pulse Output Indicator
FWD: Forward Indicator
REV: Reverse Indicator

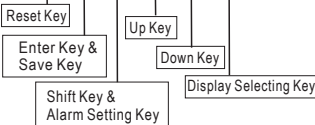

Key Name	Symbol	Descriptions
Reset Key	Z	1. Press this key to enable the reset function for total value and max. value.
Enter Key & Save Key	ENT	1. In the measuring status, press this key can enter to parameter pages. 2. In the parameter setting, press this key can save the value & go to next parameter.
Shift Key & Alarm Setting Key	AL	1. In the measuring page, press this key for 3 sec can enter to alarm setting page (The selecting digit will be flashed) 2. In the parameter setting, press this key can move the cursor left.
Up Key	GUP	1. In the parameter setting, press this key can increase the digits.
Down Key	DWN	1. In the parameter setting, press this key can decrease the digits.
Display Switching Key	CHN	1. In the measuring page, press this key can switch the display pages.

- **1. The following block charts are parameters codes, parameter codes & parameters will alternate flashing if the parameters can be modified.
- To modify the parameters, please press **E** ← ↑, and press **E** to save the parameter after the modification.
 - Please don't forget the new pass code after modification.
 - In any pages, press ↑ & ↓, or don't press any keys for 2 minutes that will back to measuring status.

GENERAL MODE OPERATING PROCEDURES

Block Charts	Display	Descriptions	Default
Alarm Setpoint			
	Measuring Status	Present value for measurement	
	Alarm 1 Setpoint (AL1)	Press E ← ↑ to modify alarm 1 setpoint. P.S.: Alarm value is set by the Secondary value.	00000
	Alarm 2 Setpoint (AL2)	Press E ← ↑ to modify alarm 2 setpoint. P.S.: Alarm value is set by the Secondary value.	00000

- Remark: 1. There are 3 parameter groups of "System Setting Group(SYS)", "Alarm Setting Group(roP)", "RS485 Setting Group(doP)" for modification.
2. Press **E** to select each group page, and press **E** to enter each group or parameter page for modification or saving the parameters.
3. Some of optional functions of parameter pages still exist, but the functions are disable.
4. The data catch by RS-485 must use K factor for Bit Conversion table to convert the Secondary value of each power parameters.

PROGRAMMING MODE OPERATING PROCEDURES

Block Charts	Display	Descriptions	Default
Parameter Group Setting Procedures			
	Measuring Status	Present value for measurement.	
	Pass Code (P.Cod)	Press E ← ↑ to enter pass code. Pass code is correct that will enter to parameter groups. Pass code is wrong that will back to measuring status.	00000
<p>System Setting Group (SYS) Alarm Setting Group (roP) RS485 Setting Group (doP)</p>			

Display	Descriptions	Default	
System Setting Group Procedures			
	System Setting Page (SYS) System Connection Setting (Conn.) PT Ratio Setting (Pt.r) CT Ratio Setting (Ct.r) Demand Time Setting (dEM.t) Pass Code Setting (CodE) Auto Display Switching Setting (Auto) Key Lock Setting (LoCK)	Press \uparrow \downarrow to select system connection. (3P4W, 3P3W, 1P3W, 1P2W) Press \leftarrow \rightarrow to modify PT ratio (1~9999). Press \leftarrow \rightarrow to modify CT ratio (1~9999). Press \leftarrow \rightarrow to modify demand time (1~60 min). Press \leftarrow \rightarrow to modify pass code (0~19999). PS: Please don't forget the new pass code after modification. Press \uparrow \downarrow to select auto display switching off (YES) or on (NO). (Display period: 10sec per page) Press \uparrow \downarrow to lock the keys, using key lock function only can view the parameters, but cannot modify any values. PS: no (unlock), YES ("ENT" unlock, others lock).	3P4W / / / 00000 no no
Alarm Setting Group Procedures			
	Alarm Setting Page (roP) Alarm 1 Selection Setting (SEL1) Alarm 1 Action Setting (Act1) Alarm Hysteresis Setting (HYS1) Alarm Run Delay Setting (dEL1) Alarm Start Band Time Setting (Sdt1) Alarm Start Band Setting (Sb1) Alarm 1 Selection Setting (SEL2) Alarm 1 Action Setting (Act2) Alarm Hysteresis Setting (HYS2) Alarm Run Delay Setting (dEL2) Alarm Start Band Time Setting (Sdt2)	The following steps are only available for alarm output. Press \uparrow \downarrow to select alarm 1 selection. (VE, AE, AN, Σ W, Σ Q, Σ S, Σ PF, DEMA, MAX.D) Press \uparrow \downarrow to modify alarm value that is \geq (Hi) or $<$ (Lo) for alarm action. Press \leftarrow \rightarrow to modify the value, when alarm runs lower or higher display value (depends on alarm action). Alarm setpoint \pm this value (0~99) will turn off the alarm. Press \leftarrow \rightarrow to modify the value, when the display value reach the alarm value that need to wait for this time (0~99 sec) for alarm action. Press \leftarrow \rightarrow to modify the value (0~99 sec), if the display value reach alarm start band value; the alarm will be act after this value (sec). (The function is used with "Sb" function.) Press \uparrow \downarrow to modify the value (-99~+99), if the display value don't over this range; the alarm will not be act. Press \uparrow \downarrow to select alarm 2 selection. (VE, AE, AN, Σ W, Σ Q, Σ S, Σ PF, DEMA, MAX.D) Press \uparrow \downarrow to modify alarm value that is \geq (Hi) or $<$ (Lo) for alarm action. Press \leftarrow \rightarrow to modify the value, when alarm runs lower or higher display value (depends on alarm action). Alarm setpoint \pm this value (0~99) will turn off the alarm. Press \leftarrow \rightarrow to modify the value, when the display value reach the alarm value that need to wait for this time (0~99 sec) for alarm action. Press \leftarrow \rightarrow to modify the value (0~99 sec), if the display value reach alarm start band value; the alarm will be	uE Hi 00000 00000 00000 00000 00000 uE Hi 00000 00000

Display	Descriptions	Default	
	Alarm Start Band Setting (Sb2)	act after this value (sec). (The function is used with "Sb" function.) Press \uparrow \downarrow to modify the value (-99~+99), if the display value don't over this range; the alarm will not be act.	00000
RS485 Setting Group Procedures			
	RS485 Setting Page (doP) Address Setting (Addr) Baud Rate Setting (bAUd) Parity Setting (PARi) Frame Setting (FrAmE)	The following steps are only available for RS-485. Press \leftarrow \rightarrow to modify address (0~255). Press \uparrow \downarrow to select baud rate (38400/19200/9600/4800); Press \uparrow \downarrow to select parity (n.8.2/n.8.1/even/odd). Press \uparrow \downarrow to select frame type. (NO:Hi \rightarrow Lo, YES:Lo \rightarrow Hi)	00000 1942 n8.2 no

Error Code of Self-Diagnosis

Display	Descriptions
oFL	Input signal is over 120% of input range.
-oFL	Input signal is under -20% of input range.
AdEr	Input signal is over 180% of input range or meter error.
doFL	Input signal is over display range (99999)
-doFL	Input signal is under display range (-19999)
E-00	EEPROM reading/writing suffers the interference (about 1 million times).

**Please check the wiring connection is correct first, if the problem still exist, please return the meter to the factory.

Modbus RTU Mode Protocol Address Table

Data: 16Bit/32Bit, +/- is 8000~7FFF (-32768~32767), 80000000~7FFFFFFF (-2147483648~2147483647)

Modbus	HEX	Name	Descriptions	Act
40001	0000	ID	Model number identification; APM is "14"	R
40002	0001	STATUS	Current status display; range: 0000~00FF(0~254) (0:OFF, 1:ON) (Bit7:AL2, Bit6:AL1, Bit5:OC2, Bit4:OC1, Bit3:D12, Bit2:D11)	R
40003	0002	ACT	Alarm act setting; range 0000~0001(0~1) 0:Hi, 1:Lo (Bit0:ACT1, Bit4:ACT2)	R/W
40004	0003	FRAME	Frame setting; range 0000~0001(0~1) 0:NO, 1:YES	R/W
40005	0004	AUTO	Auto display switching setting; range: 0000~0001 (0~1) 0:NO, 1:YES	R/W
40006	0005	LOCK	Key lock setting; range: 0000~0001 (0~1) 0:NO, 1:YES	R/W
40007	0006	CONN	System connection setting; range: 0000~0003 (0~3) 0:3P4W, 1:3P3W, 2:1P3W, 3:1P2W	R/W
40008	0007	SEL1	Alarm 1 selection setting; range: 0000~0008 (0~8) 0:VE, 1:AE, 2:AN, 3:ΣW, 4:ΣQ, 5:ΣS, 6:ΣPF, 7:DMEA, 8:MAX.D	R/W
40009	0008	SEL2	Alarm 2 selection setting; range: 0000~0008 (0~8) 0:VE, 1:AE, 2:AN, 3:ΣW, 4:ΣQ, 5:ΣS, 6:ΣPF, 7:DMEA, 8:MAX.D	R/W
40010	0009	V.SCL	Volt scale setting; range: 0000~0002 (0~2) 0:150V, 1:300V, 2:600V	R/W
40011	000A	A.SCL	Amp scale setting; range: 0000~0001 (0~1) 0:5A, 1:1A	R/W
40012	000B	BAUD	Baud rate setting; range: 0000~0003 (0~3) 0:38400, 1:19200, 2:9600, 3:4800	R/W
40013	000C	PARI	Parity setting; range: 0000~0003 (0~3), 0:N.8.2., 1:N.8.1., 2:EVEN, 3:ODD	R/W
40014	000D	DEMT	Demand time setting; range: 0001~003C (1~60)	R/W
40015	000E	HYS1	Alarm 1 hysteresis setting; range: 0000~0063 (0~99)	R/W
40016	000F	HYS2	Alarm 2 hysteresis setting; range: 0000~0063 (0~99)	R/W
40017	0010	DEL1	Alarm 1 act delay time setting; range: 0000~0063 (0~99)	R/W
40018	0011	DEL2	Alarm 2 act delay time setting; range: 0000~0063 (0~99)	R/W
40019	0012	SB1	Alarm 1 start band setting; range: FF9D~0063 (-99~99)	R/W
40020	0013	SB2	Alarm 2 start band setting; range: FF9D~0063 (-99~99)	R/W
40021	0014	SDT1	Alarm 1 start delay time setting; range: 0000~0063 (0~99)	R/W
40022	0015	SDT2	Alarm 2 start delay time setting; range: 0000~0063 (0~99)	R/W
40023	0016	ADDR	Address setting; range: 0000~00FF (0~255)	R/W
40024	0017	CODE	Pass code setting; range: 0000~4E1F (0~19999)	R/W
40025	0018	PTR	PT ratio setpoint setting; range: 0001~270F(1~9999)	R/W
40026	0019	CTR	CT ratio setpoint setting; range: 0001~270F(1~9999)	R/W
40027	001A	AL1	Alarm 1 setpoint setting; range: D8F1~270F (-9999~9999)	R/W
40028	001B	AL2	Alarm 2 setpoint setting; range: D8F1~270F (-9999~9999)	R/W
40029	001C	MAX VE	Max. 3 Phase average volt setting; range: 0000~3A98 (0~15000)	R/W
40030	001D	MAX AE	Max. 3 Phase average amp setting; range: 0000~411A (0~16666)	R/W
40031	001E	MAX AN	Max. 3 Phase average amp of neutral setting; range: 0000~411A (0~16666)	R/W
40032	001F	MAX W	Max. 3 Phase equivalent watt setting; range: 8AD0~7530 (-30000~30000)	R/W
40033	0020	MAX Q	Max. 3 Phase equivalent var setting; range: 8AD0~7530 (-30000~30000)	R/W

Modbus	HEX	Name	Descriptions	Act
40034	0021	MAX S	Max. 3 Phase equivalent apparent power setting; range: 0000~7530 (0~30000)	R/W
40035	0022	MAX PF	Max. 3 Phase equivalent power factor setting; range: D8F0~2710 (-10000~10000)	R/W
40036	0023	MAX Hz	Max. frequency setting; range: 0000~0460 (0~1120)	R/W
40037	0024	MAX DEM	Max. demand setting; range: 0000~7530 (0~30000)	R/W
40038	0025	FWD KWH	Forward kilo watt-hour setting; range: 00000000~FFFFFFF (0~4294967295) Hi Bit	R/W
40039	0026		Forward kilo watt-hour setting; range: 00000000~FFFFFFF (0~4294967295) Low Bit	R/W
40040	0027	REV KWH	Reverse kilo watt-hour setting; range: 00000000~FFFFFFF (0~4294967295) Hi Bit	R/W
40041	0028		Reverse kilo watt-hour setting; range: 00000000~FFFFFFF (0~4294967295) Low Bit	R/W
40042	0029	FWD KQH	Forward kilo var-hour setting; range: 00000000~FFFFFFF (0~4294967295) Hi Bit	R/W
40043	002A		Forward kilo var-hour setting; range: 00000000~FFFFFFF (0~4294967295) Low Bit	R/W
40044	002B	REV KQH	Reverse kilo var-hour setting; range: 00000000~FFFFFFF (0~4294967295) Hi Bit	R/W
40045	002C		Reverse kilo var-hour setting; range: 00000000~FFFFFFF (0~4294967295) Low Bit	R/W
40046	002D	RA	R phase amp display; range: 0000~411A (0~16666)	R
40047	002E	SA	S phase amp display; range: 0000~411A (0~16666)	R
40048	002F	TA	T phase amp display; range: 0000~411A (0~16666)	R
40049	0030	R VP	R phase phase-volt display; range: 0000~3A98 (0~15000)	R
40050	0031	S VP	S phase phase-volt display; range: 0000~3A98 (0~15000)	R
40051	0032	T VP	T phase phase-volt display; range: 0000~3A98 (0~15000)	R
40052	0033	R VL	R phase line-volt display; range: 0000~657C (0~25980)	R
40053	0034	S VL	S phase line-volt display; range: 0000~657C (0~25980)	R
40054	0035	T VL	T phase line-volt display; range: 0000~657C (0~25980)	R
40055	0036	R W	R phase watt display; range: D8F0~270F (-10000~10000)	R
40056	0037	S W	S phase watt display; range: D8F0~270F (-10000~10000)	R
40057	0038	T W	T phase watt display; range: D8F0~270F (-10000~10000)	R
40058	0039	R Q	R phase var display; range: D8F0~270F (-10000~10000)	R
40059	003A	S Q	S phase var display; range: D8F0~270F (-10000~10000)	R
40060	003B	T Q	T phase var display; range: D8F0~270F (-10000~10000)	R
40061	003C	R S	R phase apparent power display; range: 0000~270F (0~10000)	R
40062	003D	S S	S phase apparent power display; range: 0000~270F (0~10000)	R
40063	003E	T S	T phase apparent power display; range: 0000~270F (0~10000)	R
40064	003F	R PF	R phase power factor display; range: D8F0~270F (-10000~10000)	R
40065	0040	S PF	S phase power factor display; range: D8F0~270F (-10000~10000)	R
40066	0041	T PF	T phase power factor display; range: D8F0~270F (-10000~10000)	R
40067	0042	AVG V	3 phase average volt amp display; range: 0000~657C (0~25980)	R
40068	0043	AVG A	3 phase average amp display; range: 0000~411A (0~16666)	R
40069	0044	AVG AN	Amp of neutral display; range: 0000~411A (0~16666)	R
40070	0045	ΣW	3 phase equivalent watt display; range: 8AD0~7530 (-30000~30000)	R
40071	0046	ΣQ	3 phase equivalent var display; range: 8AD0~7530 (-30000~30000)	R
40072	0047	ΣS	3 phase equivalent apparent power display; range: 0000~7530 (0~30000)	R
40073	0048	ΣPF	3 phase equivalent power factor display; range: D8F0~270F (-10000~10000)	R
40074	0049	HZ	Frequency display; range: 0~460 (0~1120)	R
40075	004A	DEMAND	Demand display; range: 0~7530 (0~30000)	R

DISPLAY SWITCHING INDICATION

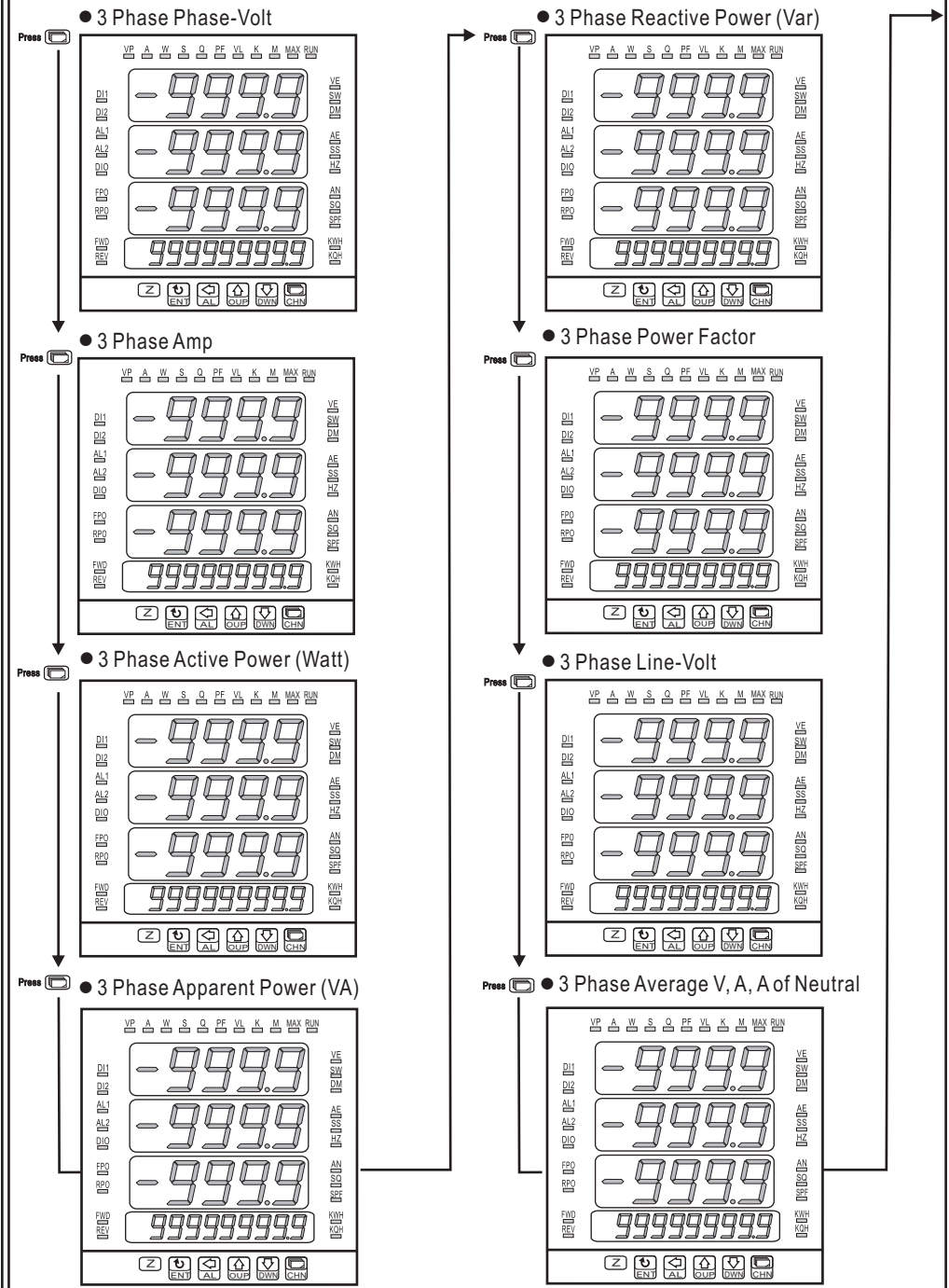

P7

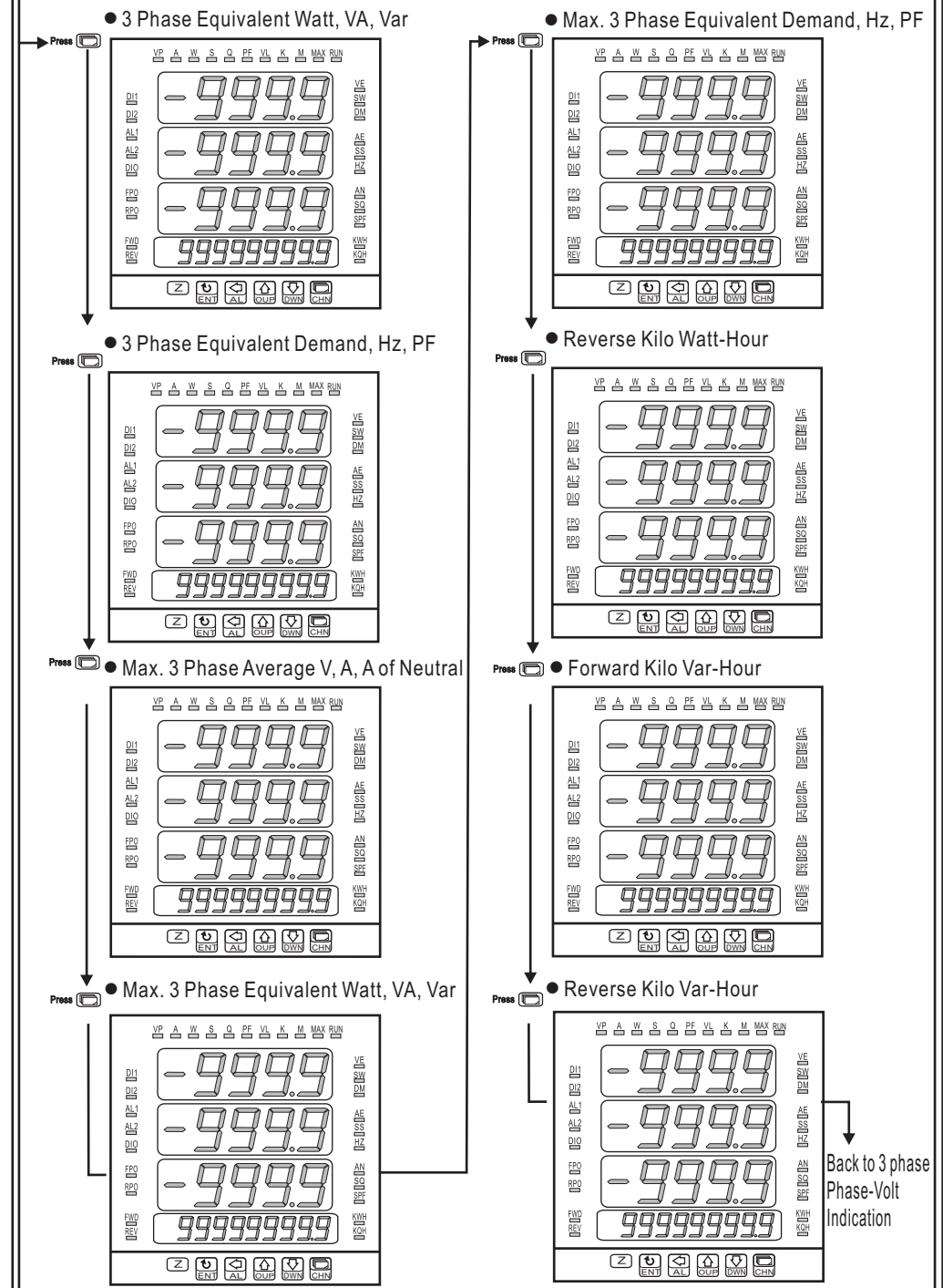

P8

WIRING CONNECTION

● 1 ϕ 2 W

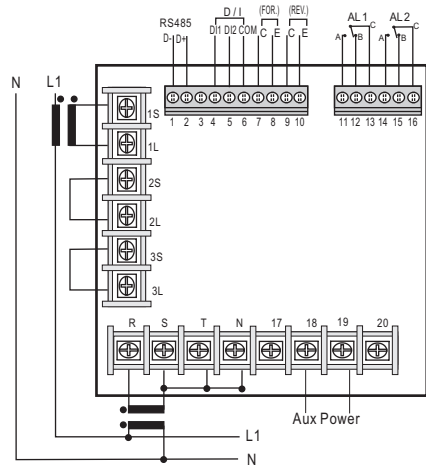

● 3 ϕ 3 W

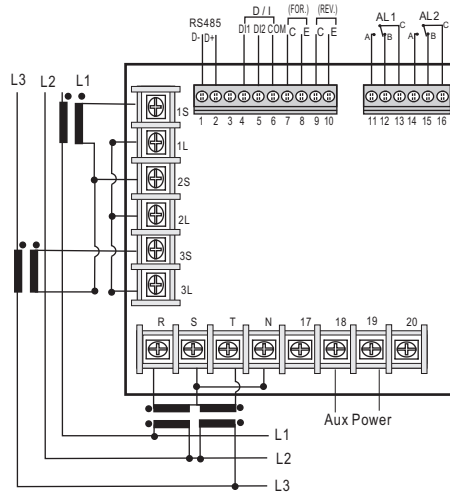

● 1 ϕ 3 W

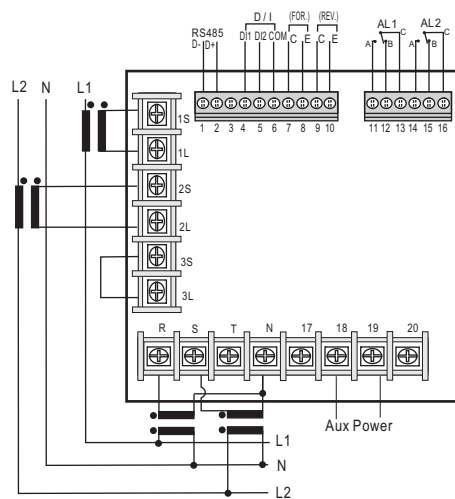

● 3 ϕ 4 W

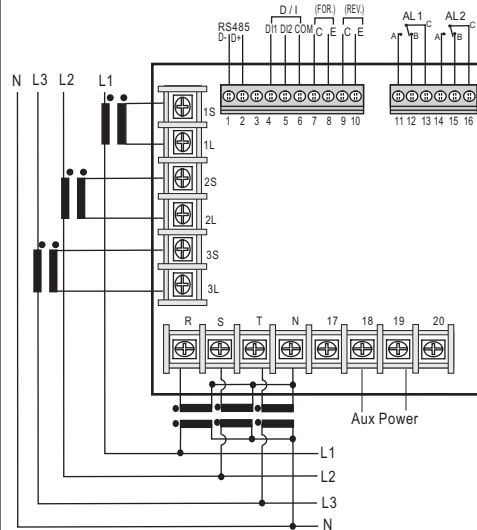

K Factors for Bit Conversion

Parameter	K Factor	Parameter	K Factor
Phase Volt	600V: 0.04	Phase Amp	5A: 0.0003
	300V: 0.02		1A: 0.00006
	150V: 0.01		
Frequency (Hz)	0.0625	Power Factor (PF)	0.0001
Phase Watt (W)	600 V / 5 A = 2000 W: 0.2	600 V / 1 A = 400 W: 0.04	
	300 V / 5 A = 1000 W: 0.1	300 V / 1 A = 200 W: 0.02	
	150 V / 5 A = 500 W: 0.05	150 V / 1 A = 100 W: 0.01	
Equivalent Watt (Σ W)	600 V / 5 A = 6000 W: 0.4	600 V / 1 A = 1200 Var: 0.08	
	300 V / 5 A = 3000 W: 0.2	300 V / 1 A = 600 Var: 0.04	
	150 V / 5 A = 1500 W: 0.1	150 V / 1 A = 300 Var: 0.02	
Phase Var (Q)	600 V / 5 A = 2000 Var: 0.2	600 V / 1 A = 400 Var: 0.04	
	300 V / 5 A = 1000 Var: 0.1	300 V / 1 A = 200 Var: 0.02	
	150 V / 5 A = 500 Var: 0.05	150 V / 1 A = 100 Var: 0.01	
Equivalent Var (Σ Q)	600 V / 5 A = 6000 Var: 0.4	600 V / 1 A = 1200 Var: 0.08	
	300 V / 5 A = 3000 Var: 0.2	300 V / 1 A = 600 Var: 0.04	
	150 V / 5 A = 1500 Var: 0.1	150 V / 1 A = 300 Var: 0.02	
Phase VA (S)	600 V / 5 A = 2000 VA: 0.2	600 V / 1 A = 400 VA: 0.04	
	300 V / 5 A = 1000 VA: 0.1	300 V / 1 A = 200 VA: 0.02	
	150 V / 5 A = 500 VA: 0.05	150 V / 1 A = 100 VA: 0.01	
Equivalent VA (Σ S)	600 V / 5 A = 6000 VA: 0.4	600 V / 1 A = 1200 VA: 0.08	
	300 V / 5 A = 3000 VA: 0.2	300 V / 1 A = 600 VA: 0.04	
	150 V / 5 A = 1500 VA: 0.1	150 V / 1 A = 300 VA: 0.02	
Forward KWH Reverse KWH	600 V / 5 A = 6000 W: 0.4	600 V / 1 A = 1200 W: 0.08	
	300 V / 5 A = 3000 W: 0.2	300 V / 1 A = 600 W: 0.04	
	150 V / 5 A = 1500 W: 0.1	150 V / 1 A = 300 W: 0.02	
Forward KQH Reverse KQH	600 V / 5 A = 6000 Var: 0.4	600 V / 1 A = 1200 Var: 0.08	
	300 V / 5 A = 3000 Var: 0.2	300 V / 1 A = 600 Var: 0.04	
	150 V / 5 A = 1500 Var: 0.1	150 V / 1 A = 300 Var: 0.02	
Forward KWH P/O Reverse KWH P/O	600 V / 5 A = 6000 W: 0.4 1 KWH = 2500 pulse	600 V / 1 A = 1200 W: 0.08 1 KWH = 12500 pulse	
	300 V / 5 A = 3000 W: 0.2 1 KWH = 5000 pulse	300 V / 1 A = 600 W: 0.04 1 KWH = 25000 pulse	
	150 V / 5 A = 1500 W: 0.1 1 KWH = 10000 pulse	150 V / 1 A = 300 W: 0.02 1 KWH = 50000 pulse	