

- The wind speed sensor transfer the wind speed to machinery speed by the cooperation of wind cup and bearing with connect parts. And transfer the machinery into electronic signal by the Non-contact magnetic sensing and electronic transfer mechanism.
- The wind speed sensor's monoblock was made of black ABS+PC.
- It has many advantages like : heatproof, low temperature resistance. It is always used in highway, port, wharf, power plant, cableway, clutivation, agriculture, energy saving detection, engineering machine ect.

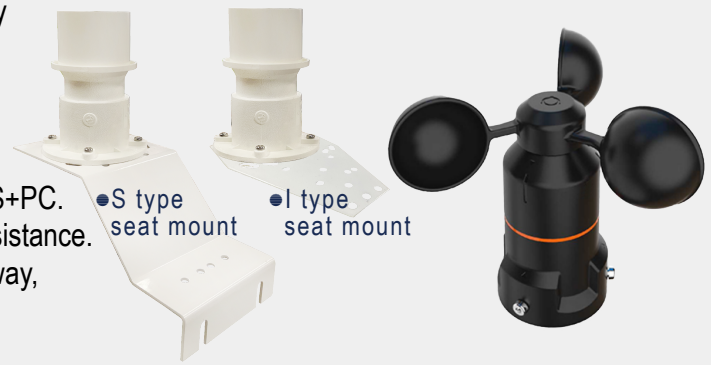

SPECIFICATION

- ◆ Measurement range: 1.0~70m/s
- ◆ Accuracy: <math><30\text{m/s}\pm(0.5+0.05v)</math>
$\geq 30\text{m/s}\pm 3\%$
- ◆ Resolution: <math><0.1\text{m/s}</math>
- ◆ Power supply: DC12-36V
- ◆ Response Time: <math><0.5\text{s}</math>
- ◆ Work environment: $-20^{\circ}\text{C}\sim+70^{\circ}\text{C}$
- ◆ Humidity: 20%-90%RH
(25°C non-condensation)

ORDER INFORMATION

WFSS- Code1

Code1 Output Signal	
A	4~20mA
Y	RS-485
O	Option

DIMENSION

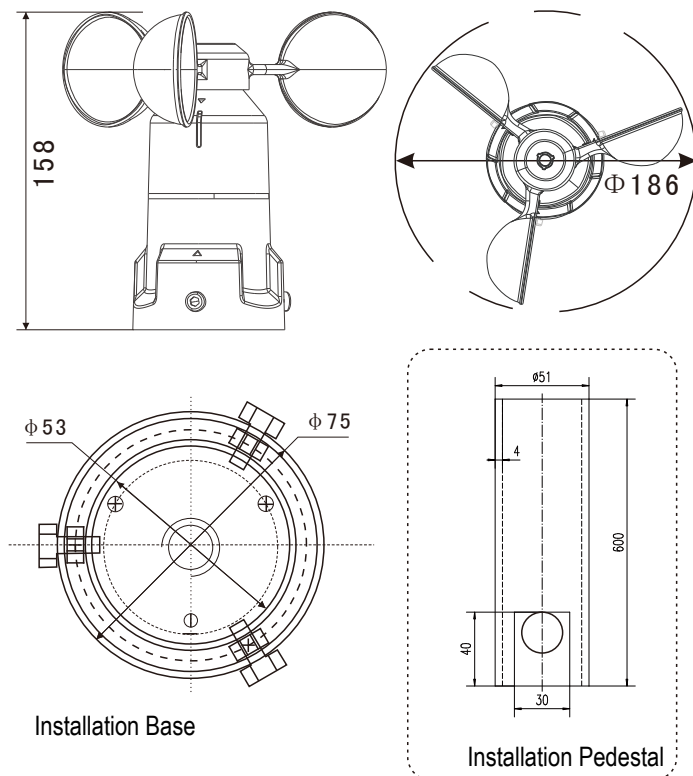

WIRING CONNECTION

- 4~20mA
 - 1: DC Power
 - 2: 4~20MA
 - 5: GND
- RS-485
 - 1: DC Power
 - 3: RS485A
 - 4: RS485B
 - 5: GND