

- Hollow shaft diameter: 30 mm
- Pulse per resolution up to 1024 PPR



SPECIFICATION

- ◆ Detection System: Incremental
- ◆ Output Wave: Square wave
- ◆ Output Phase: AB phase or ABZ phase
- ◆ Output Capacity: 20 mA
- ◆ Temperature Coefficient: 100ppm / °C (0~60°C)
- ◆ Operating Temperature: 0~60°C
- ◆ Operating Humidity: 20~90% RH (non-condensing)
- ◆ Storage Temperature: -10~70°C
- ◆ Storage Humidity: 20~90% RH (non-condensing)
- ◆ Power Supply: DC 8~26V, DC 5V
- ◆ Current Consumption: <60mA
- ◆ Waveform Rise/Fall: 2 usec
- ◆ Max. Frequency: 10KHz~100KHz
- ◆ Hollow Shaft Diameter: 30 mm
- ◆ Shaft Loading: Axial: 0.5Kgs; Radial: 1Kgs
- ◆ Starting Torque: 30 gf-cm (at 25°)
- ◆ Max. Speed: 2500 RPM
- ◆ Vibration: 10g (10 ± 1500Hz)
- ◆ Polarity: Against reverse protection (not with 5V)
- ◆ Shock: 20g/11msec
- ◆ Cable Length: 100 cm
- ◆ Weight: About 1200 g

DIMENSION

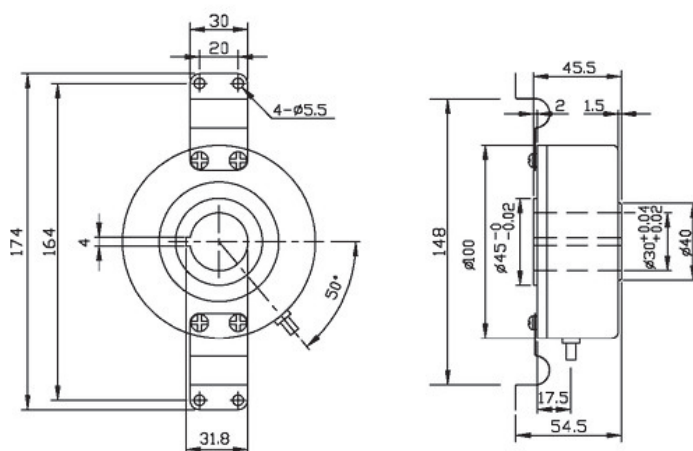

ORDER INFORMATION

HTR-HD - [Code 1] - [Code 2] - [Code 3] - [Code 4] - [Code 5]

Code1	Hollow Shaft	Code2	Pulse per Resolution	Code3	Output Phase	Code4	Output Waveform	Code5	Aux. Power
30	30 mm	200, 512, 600, 1024		2	AB Phase	Empty	Voltage	Empty	DC 8-26V
				3	ABZ Phase	C	Open Collector	5V	DC 5V
				3H	AB+Z Hi Phase	P	Push-Pull		
						L	Line-Driver 5Vdc		
						HL	Line-Driver 8~26Vdc		

OUTPUT WAVEFORM

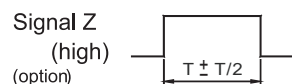
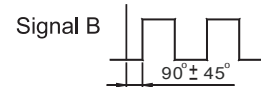
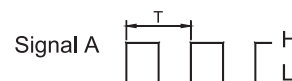

WIRING CONNECTION

● Voltage Type:

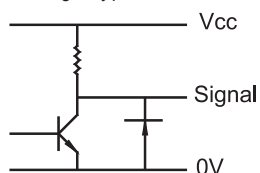

● Open-Collector:

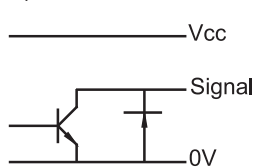

● Line Driver:

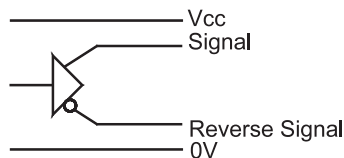

● Push-Pull:

