

WIRING CONNECTION

● Voltage, Current (AC, DC)

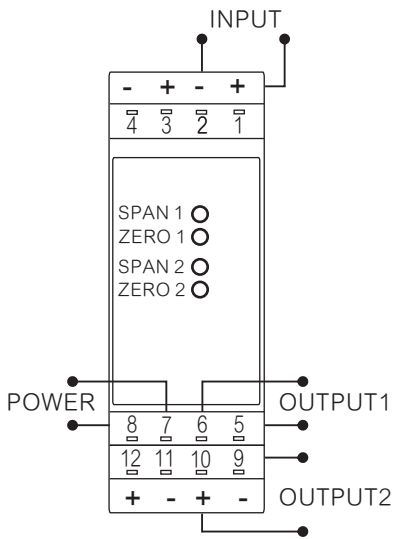

● 2,3 Wire Sensor

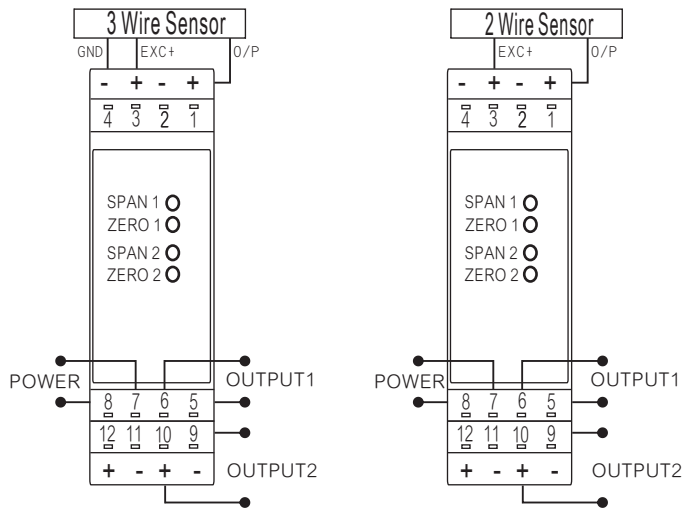

● Temperature (RTD)

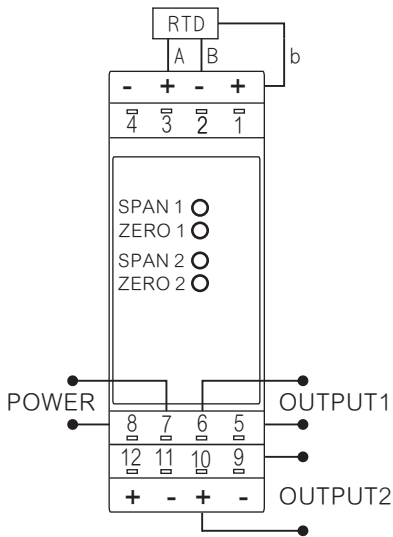

● 4 Wire Sensor or Load cell

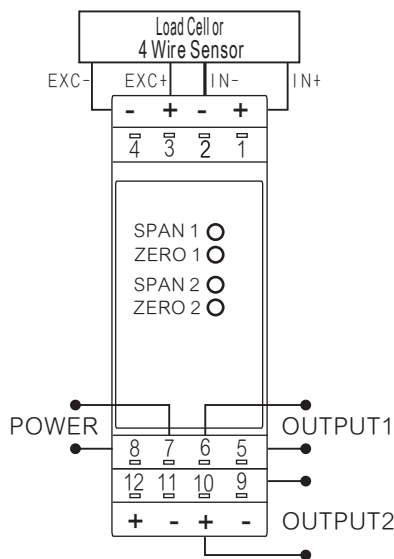

● 3 Wire Potentiometer

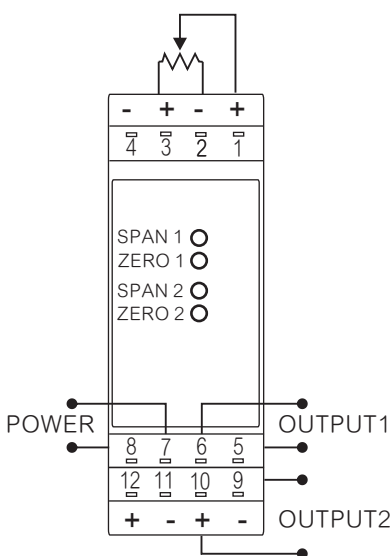

● 2 Wire Resistor

