

- 材質: 鋁合金
- 可依客戶需求訂製



選用型號規格

SCT - 代碼1 - 代碼2

碼1	孔徑1	碼2	孔徑2
6	6 mm	6	6 mm
0	Option	0	Option

尺寸圖

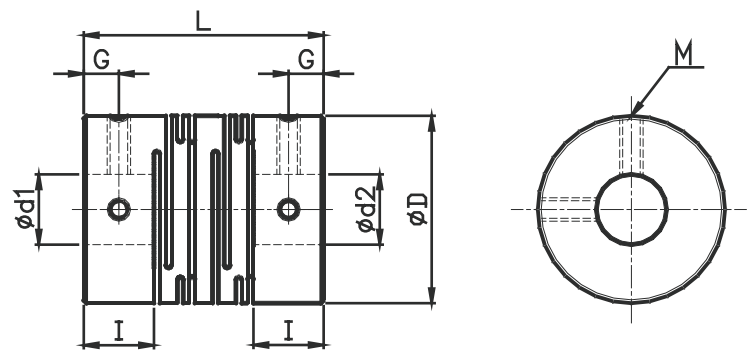

規格特性

Type	Material	Diameter (D)	Length (L)	G	Screw	Wrench Torque	Bore (mm)	Rage Torque (N.M)	Max. Torque (N.M)	Errors of Angularity (degree)	Maxx (g)
SCT-16	Aluminum alloy	16 mm	23 mm	3	M3	0.7 Nm	4 ~ 8	0.3	0.6	2	8.1
SCT-20		20 mm	26 mm	3	M4	0.7 Nm	5 ~ 10	0.5	1	2	14
SCT-25		25 mm	31 mm	4	M4	1.7 Nm	6~12	1	2	2	27

*Other sizes of hole or difference bore is available by request.