

- 輸出信號: 方波
- 量測行程: 200, 500, 1000 mm
- 脈波解析度: 1mm; 0.5 mm; 0.2 mm; 0.1 mm; 0.04 mm
- CE認證

規格特性

- ◆ 檢測系統: 增量型
- ◆ 輸出波形: 方波
- ◆ 輸出相: AB相, ABZ相
- ◆ 輸出容量: 20 mA
- ◆ 溫度係數: 100ppm/°C (0~60°C)
- ◆ 使用環境溫.濕度: 0~60°C; 20~90% RH (非結露)
- ◆ 存放環境溫.濕度: -10~70°C; 20~90% RH (非結露)
- ◆ 工作電源: DC 8~26V; DC 5V
- ◆ 消耗電流: < 60 mA
- ◆ 最大反應頻率: 10KHz~100KHz
- ◆ 波形上下時間: 2 usec
- ◆ 線徑規格: 0.6mm SUS304 with Nylon coated
- ◆ 起動拉力: 1500~2000 g
- ◆ 最大容許速度: 1000 mm/sec
- ◆ 極性保護: Against reverse protection
- ◆ 出線長度衝擊: 100 cm
- ◆ 重量: < 450 g

尺寸圖

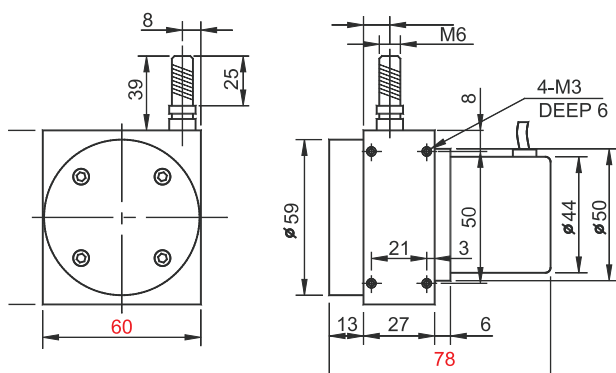

選用型號規格

HLS-S- [代碼1] - [代碼2] - [代碼3] - [代碼4] - [代碼5]

碼1	量測行程	碼2	解析度	碼3	輸出相	碼4	輸出波形	碼5	工作電源
02	200 mm	1	1 mm / pulse	Empty	AB Phase	Empty	Voltage	Empty	DC 8~26V
05	500 mm	0.5	0.5 mm / pulse	Z	ABZ Phase	C	Open Collector	5V	DC 5V
10	1000 mm	0.2	0.2 mm / pulse			P	Push-Pull		
		0.1	0.1 mm / pulse			L	Line-Driver 5Vdc		
		0.04	0.04 mm / pulse			HL	Line-Driver 8~26Vdc		

輸出波形

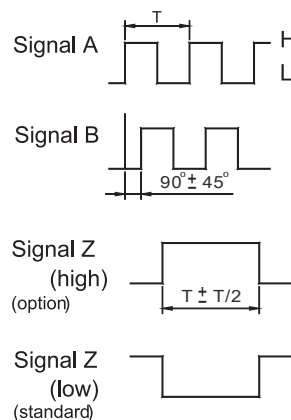

配線圖

● Voltage Type:

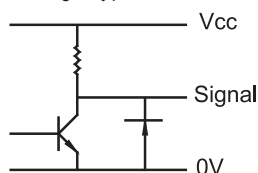

● Open-Collector:

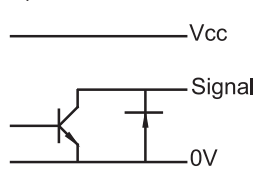

● Line Driver:

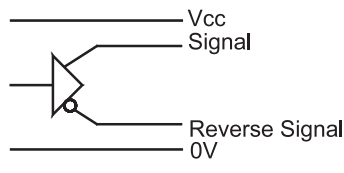

● Push-Pull:

